

INSTALLATION INSTRUCTIONS

Model Numbers

TUB / SHOWER ENCLOSURES
TE1400-2 / SE1400-2

High Light Series Frameless Bypass Tub / Shower Enclosure

When Ordering Repair Parts, Please
Give The Following Information:

1. Model Number
2. Part Number
3. Part Description
4. Color

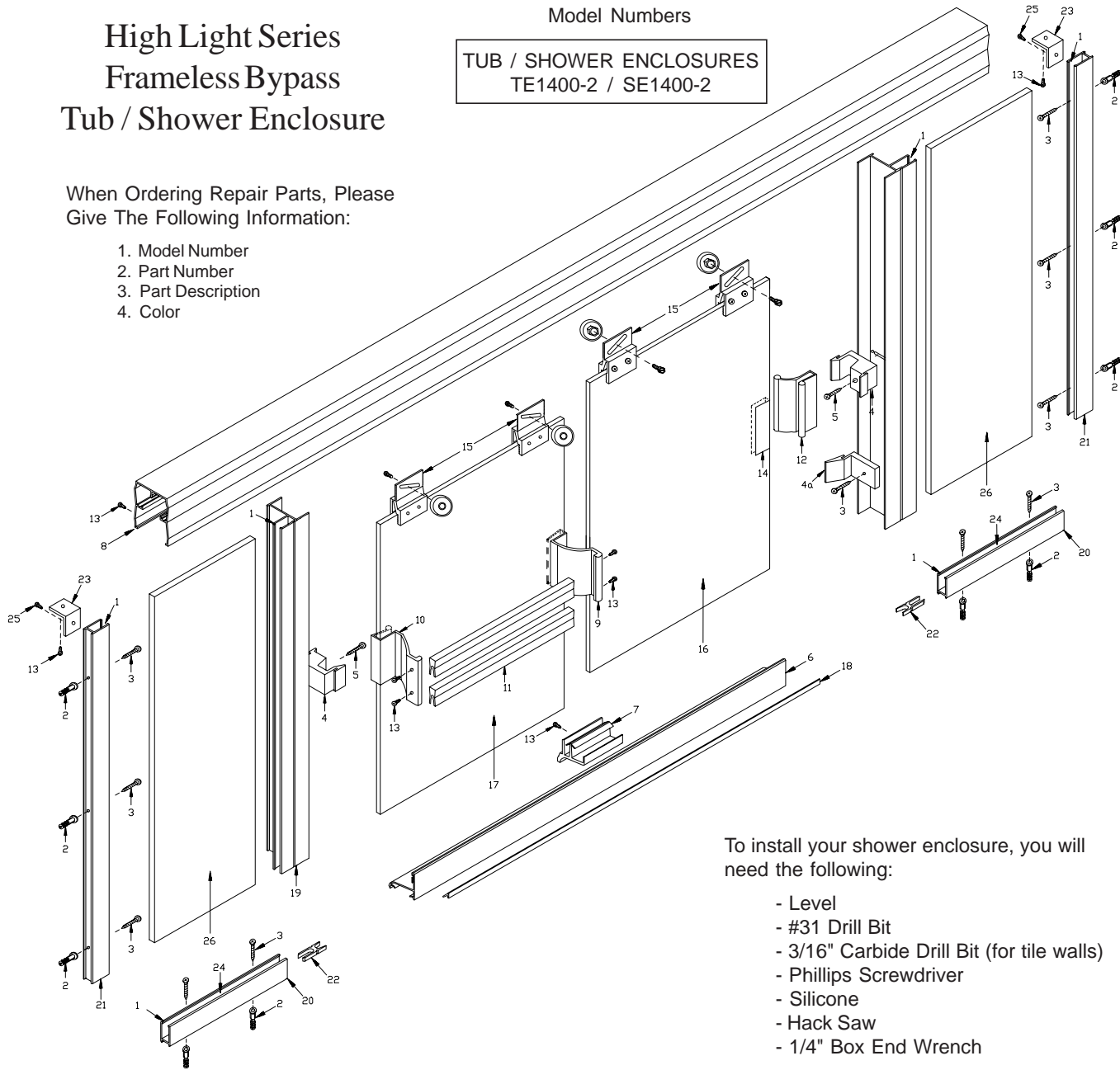

To install your shower enclosure, you will
need the following:

- Level
- #31 Drill Bit
- 3/16" Carbide Drill Bit (for tile walls)
- Phillips Screwdriver
- Silicone
- Hack Saw
- 1/4" Box End Wrench

Description	Qty.	Part #	Picture
1. Vertical Seal Vinyl	12	V-909	
2. Wall Anchors	9	HWANCHOR	
3. #8 x 1 1/2" SMS Screws	9	#8 x 1 1/2"SMS	
4. Door Bumpers	2	V-924	
4a. Bottom Bumper	1	V-926	
5. 6-32 x 1/2" MS Screws	2	6-32 x 1/2" MS	
6. Bottom Sill (with V-918)	1	TE-1522	
7. Center Guide - 3"	1	V-530	
8. Header	1	TE-1201	
9. Towel Bar Bracket	1	TE-1206	
10. Towel Bar Bracket With Pull	1	TE-1206P	
11. Towel Bars	2	TE-1205	
12. Inside Door Pull	1	TE-1207	
13. #6 x 3/8" SMS Screws	10	#6 x 3/8" SMS	
14. Handle Vinyl	1	V-916	
15. Roller Bracket Assembly	4	TE-1208-F	
16. Inside Glass Panel	1	Inside Slider	
17. Outside Glass Panel	1	Outside Slider	
18. Door Guide Vinyl (with TE-1522)	1	V-918	
19. 180-Degree Post	2	TE-1218	
20. Curb Channels	2	D-1006	
21. Wall Channels	2	D-1006	
22. Post To Curb Keys	2	C-180-3/16	
23. Clips	2	D-90-15/16	
24. Glass Support Blocks	2	V-902	
25. #6 x 1/4" SMS B Screws	2	#6x1/4SMSB	
26. Glass Panels	2		

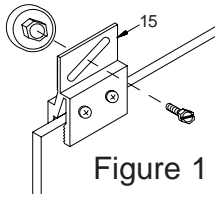

Figure 1

Note: Apply a bead of silicone (GE1200) into the open channel of roller bracket before attaching to glass. To assemble roller bracket (15) to glass, tighten screws until surface of roller bracket is depressed 1/32" (28 inchofounds of torque). Allow to cure for 24 hours before hanging sliders.

1. For 30" wide sliders deduct 60" from opening width and divide by two and subtract 7/8" to arrive at length of channel curbs (20).
2. Set channel curbs (20) temporarily in place on curb, inside edge of

channel curb should be set 1/4" to outside of center of curb. Set wall channels (21) in place on curbs, hold plumb and mark screw hole locations.
3. Remove wall channels and channel curbs. Drill 3/16" holes in walls, and insert plastic screw anchors (2).
4. Run bead of silicone full length, to underside of channel curbs (20). Set channel curbs in place

with weep holes to the inside. Fill channel with silicone where curb meets wall. Set wall channels in place and secure with # 8 x 1 1/2" SMS (3). Secure clips (23) to top inside of wall channels with a #6 x 1/4" SMS (25).
5. Place glass support block (24) in center of channel curbs. Set panels (26) in place in curbs and into wall channels. Insert post to curb keys (22)
6. Caulk curb where 180-degree post (19) will set. Fill channel of 180-degree post with silicone, opposite bumper location, to help support post on panel. Set 180-degree post in place over edge of panel, hold plumb and insert vertical seal vinyl (1) into wall channel

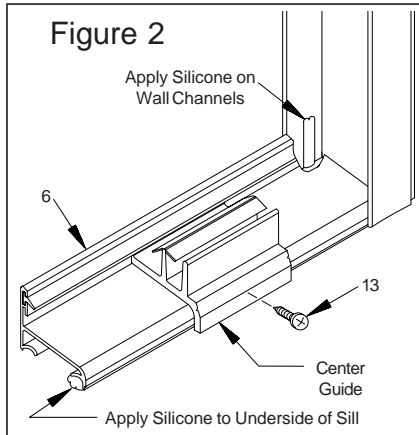
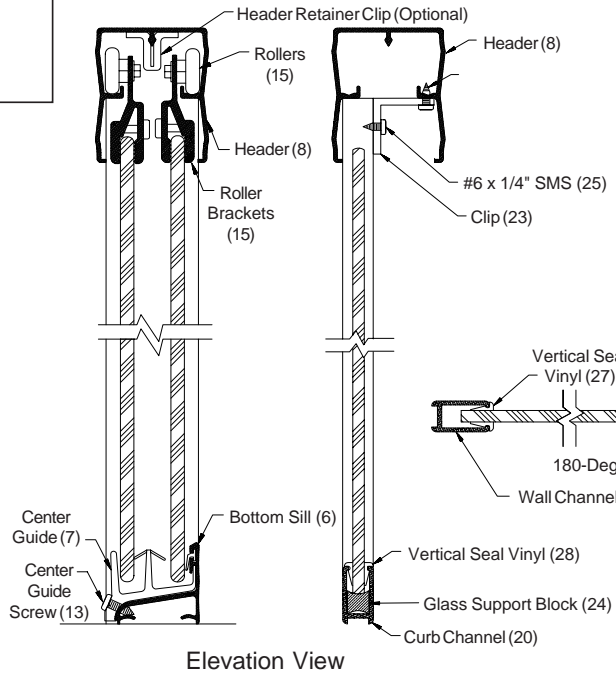

Figure 2

and post on both sides of panel. Insert vertical seal vinyl into channel curb on both sides of panel.
7. Measure between 180-degree post (19) at the curb and use this measurement to cut bottom sill (6) to length. Run a bead of silicone, full length to underside of sill and press firmly in place on curb.
8. Cut header (8) 1/32 to 1/16" less than opening width and set in place over 180-degree posts and wall channels. Secure header to 180-degree posts and wall channel clips (23) with #6 x 3/8" SMS (13)
9. To set slider glass in place, hold inside slider panel (16) inside of tub or shower pan, insert rollers up into header and lower into place. Next, insert lower end of outside



Elevation View

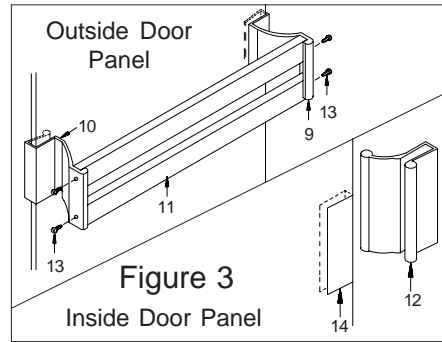

Figure 3

panel so it does not fall and break. Adjust inside slider as low as possible to reduce the gap between bottom of slider and sill taking care that the glass does not drag on the sill (6) or center guide (7). Adjust for bowed glass by using the slotted hole in the jamb. Secure bumpers (4) to the jambs using 6-32 x 1/2" screws (5).
11. Set handle vinyl (14) in place over edges of outside glass panel (17) with bottom of vinyl in line with bottom of bumper (4). Tap towel bar brackets (9 & 10) in place (See Figure 3). Bracket with pull (10) should be to jamb side of slider opposite shower head. Assemble towel bars (11) to brackets using #6 x 3/8" SMS (13).
12. Set handle (12) in place over edge of inside glass panel (16) with bottom of vinyl in line with bottom of bumper on edge facing the wall jamb. Tap inside door pull (12) in place.
Note: Large Portion of Pull to Inside of Slider.
13. Silicone inside of shower where jambs meet walls and sill meets rim of tub.

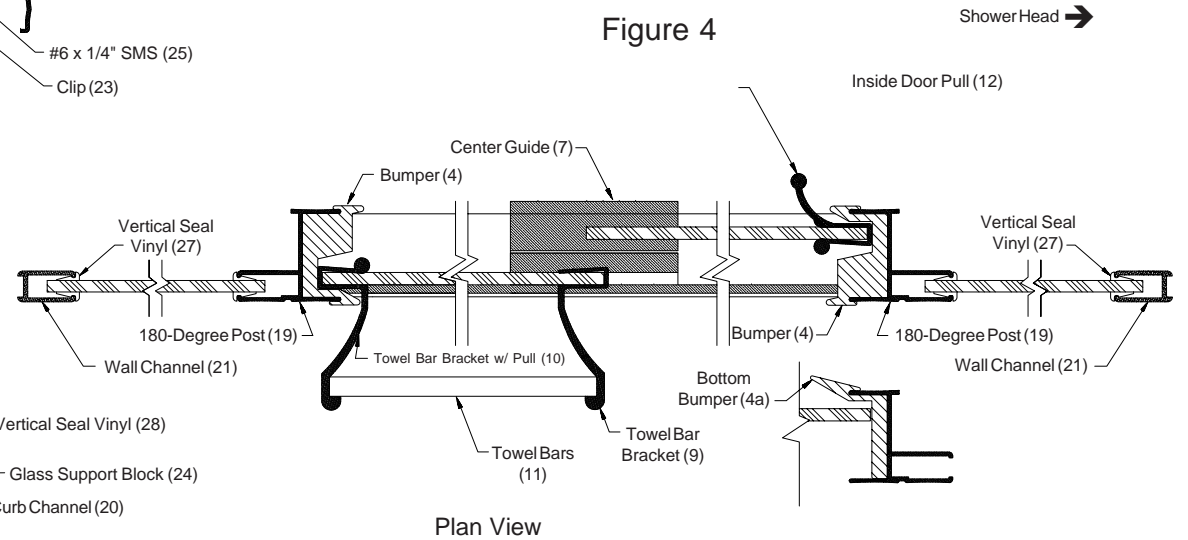

Figure 4

Plan View