

INSTALLATION INSTRUCTIONS

Model Numbers

TUB / SHOWER ENCLOSURES
TE1400-3 / SE1400-3

High Light Series Frameless Bypass Tub / Shower Enclosure

When Ordering Repair Parts, Please
Give The Following Information:

1. Model Number
2. Part Number
3. Part Description
4. Color

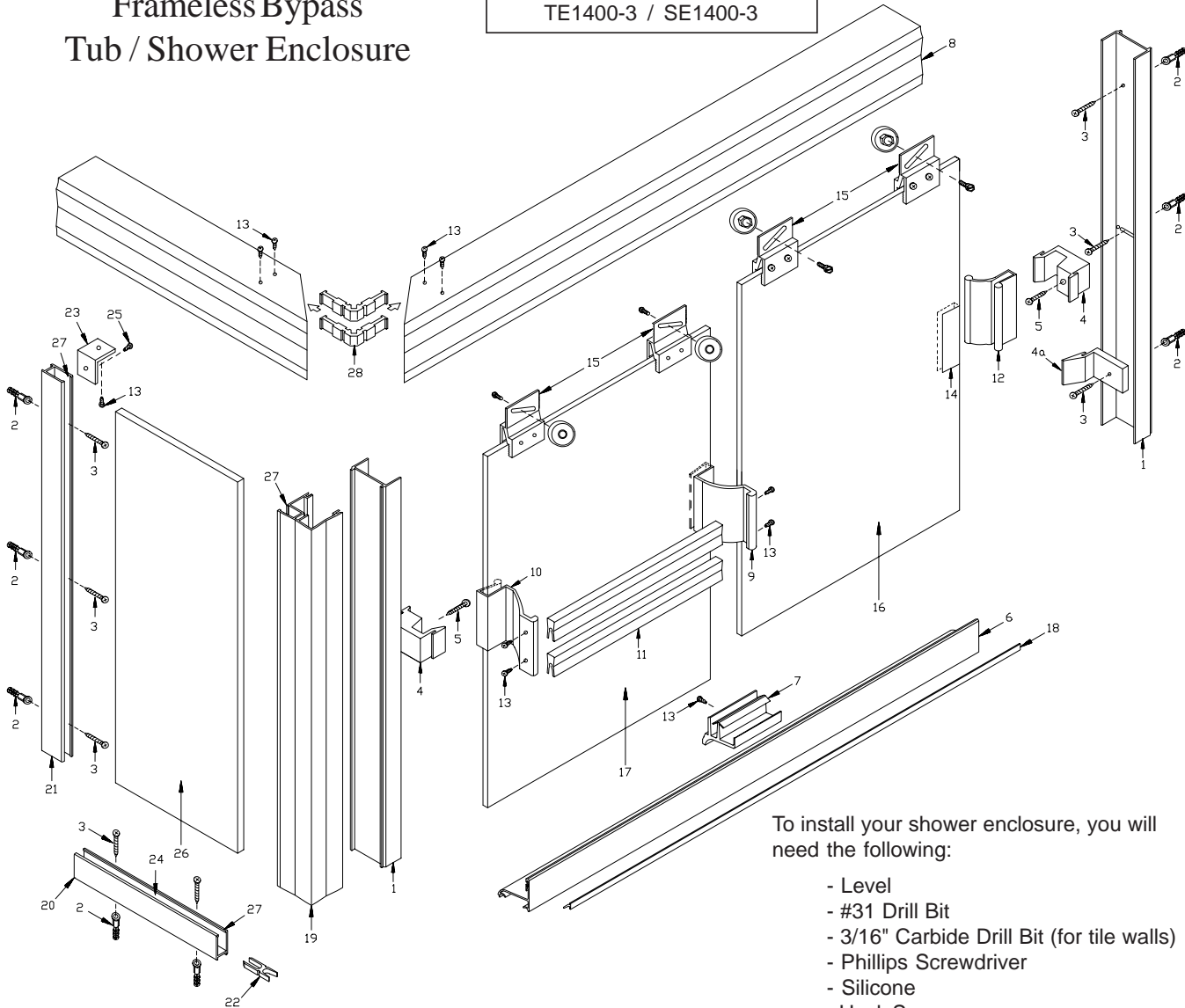

To install your shower enclosure, you will need the following:

- Level
- #31 Drill Bit
- 3/16" Carbide Drill Bit (for tile walls)
- Phillips Screwdriver
- Silicone
- Hack Saw
- 1/4" Box End Wrench

Description	Qty.	Part #	Picture
1. Wall Jamba	2	TE-1203	
2. Wall Anchors	9	HWANCHOR	
3. #8 x 1 1/2" SMS Screws	9	#8 x 1 1/2" SMS	
4. Door Bumpers	2	V-924	
4a. Bottom Bumper	1	V-926	
5. 6-32 x 1/2" MS Screws	2	6-32 x 1/2" MS	
6. Bottom Sill (with V-918)	1	TE-1522	
7. Center Guide - 3"	1	V-530	
8. Headers - Mitered	2	TE-1201	
9. Towel Bar Bracket	1	TE-1206	
10. Towel Bar Bracket With Pull	1	TE-1206P	
11. Towel Bars	2	TE-1205	
12. Inside Door Pull	1	TE-1207	
13. #6 x 3/8" SMS Screws	10	#6 x 3/8" SMS	
14. Handle Vinyl	1	V-916	
15. Roller Bracket Assembly	4	TE-1208-F	
16. Inside Glass Panel	1	Inside Slider	
17. Outside Glass Panel	1	Outside Slider	
18. Door Guide Vinyl (with TE-1522)	1	V-918	
19. 90-Degree Post	1	TE-1214	
20. Curb Channel	1	D-1006	
21. Wall Channel	1	D-1006	
22. Post To Curb Key	2	C-180-3/16	
23. Post-to-Header Clip	1	D-90-15/16	
24. Glass Support Block	1	V-902	
25. #6 x 1/4" SMS B Screws	1	#6x1/4SMSB	
26. 90-Degree Glass Panel	1		
27. Small Wedge Vinyl	6	V-909	
28. 90-Degree Header Clip	2	A-90-3132	

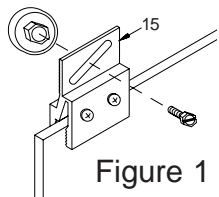

Figure 1

Note: Apply a bead of silicone (GE1200) into the open channel of roller bracket before attaching to glass. To assemble roller bracket (15) to glass, tighten screws until surface of roller bracket is depressed 1/32" (28 inchpounds of torque). Allow to cure for 24 hours before hanging sliders.

- Using a straight edge, draw a line down the center on the top of the tub rim or pan curb. (The lines should cross in the center of the front corner).
- Set jamb (1) in place on wall, centering bottom of jamb on rim of tub.

Hold plumb and mark wall for screw holes.

- Remove jamb (1) and drill 3/16" hole and insert plastic screw anchors (2).
- Silicone where the wall meets the rim of the tub to seal bottom corner of jamb. Set jamb (2) in place and secure with #8 x 1 1/2" screws (3). Secure bottom bumper (4a) on showerhead side with bottom jamb screw.
- Measure, on end panel side, from back wall to center of front corner where lines, cross. Deduct 3/4" from this measurement and cut curb channel (20) to length. Run a bead of silicon on underside of curb channel and set curb channel in place on center of curb, (Weep holes to inside). Slide post to curb key (22) onto curb channel (20) and move to the wall. Vertical wall channel will key over exposed end.

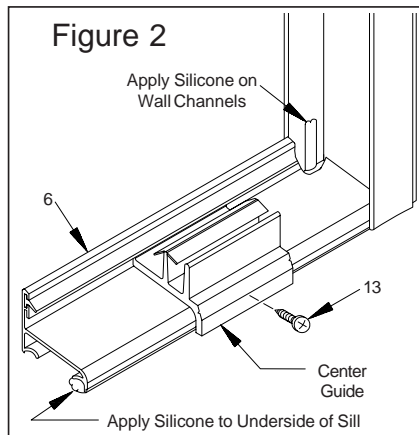

Figure 2

curb channel and wall channel. Insert vertical seal vinyl (27) into wall channel on both sides of the panel.

- Set wall channel (21) onto curb channel, hold plumb and mark screw hole locations. Remove wall channel and drill 3/16" holes and insert plastic anchors (2). Fill curb channel with silicone where curb channel meets wall and set wall channels in place. Secure wall channel using #8 x 1 1/2" SMS (3). Secure header clip (23) to inside leg of wall channel with a #6 x 1/4" screw (25).
- Place glass support blocks (24) in place in curb channel. Set panel (26) in place in curb channel and wall channel.
- Insert clip (22) into curb channel and apply a layer of silicone to curb where 90 post will set. Set corner post (19) in place over edge of panel glass and curb clip, hold plumb and insert vertical seal vinyl (27) into post and curb channel on both sides of panel glass.
- Measure from inside of wall jamb to inside of 90 post and use this measurement to cut sill (6) to length. Run a bead of silicone full length to underside of sill and apply silicone in corners where wall jamb and corner post meet curb and press guide firmly into place on curb (See Figure 2).
- Assemble header (8) using 90 clips (28) and #6 x 3/8" SMS (13). Measure from both walls to outside corner of corner post (plumb in both directions) and add 3/16" to this measurement for header length. Cut header to length and set in place over jamb (1), corner post (19) and wall channel (21). Secure header to jamb and corner post from inside of shower and to clip (23) attached to wall channel with #6 x 3/8" SMS.

- To set slider glass in place, hold inside slider panel (16) inside of tub or shower pan, insert rollers up into header and lower into place. Next, insert lower end of outside slider (17) in front of

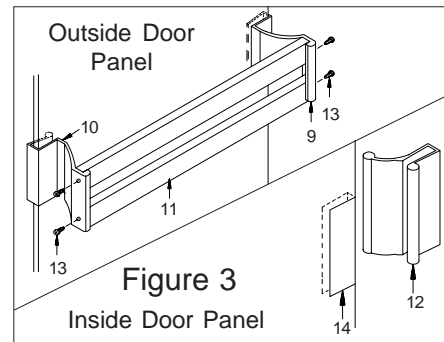

Figure 3

inside slider by pushing lower ends far enough in, to allow clearance on inside edge of tub or pan. Avoid roller bracket to roller bracket contact while lifting panel into place. The outside slider will close against the jamb opposite the showerhead.

- Place center guide (7) to center position on sill (6). Make sure the center guide is hooked into the slot position on the sill, then drill a hole using a #31 drill bit and fasten center guide to sill with the #6 x 3/8" screw (13) provided.
- Close panels and adjust to align the vertical edge of panels with jamb and post. Using a 1/4" box-end wrench, loosen the screws on the rollers,

but don't remove completely. When screws are loose, adjust panel by sliding the screw in the slot. **Note:** when screws are loose be sure to support panel so it does not fall and break. Adjust inside slider as low as possible to reduce the gap between bottom of slider and sill taking care that the glass does not drag on the track or center guide. Adjust for bowed glass by using the slotted hole in the jamb.

- Install bumpers (4) to jamb and corner post with a 6-32 1/2" screw (5). **NOTE:** Glass panels close into the recessed portion of Bumpers (4). The recess is toward the inside of the tub on the showerhead jamb and toward the outside on the corner post.

- Set handle vinyl channel (14) in place over edges of outside glass panel (17) with bottom of vinyl in line with bottom of bumper. Tap towel bar brackets (9 & 10) in place. Bracket with pull (10) should be to jamb side of slider opposite shower head. Assemble towel bars (11) to brackets using #6 x 3/8" SMS (13)

- Set handle in vinyl (14) in place over edge of inside glass panel with bottom of vinyl in line with bottom of bumper on edge facing the wall jamb. Tap inside door pull (12) in place. Note: Large Portion of Pull to Inside of Slider.

- Silicone inside of shower where jambs meet walls and sill meets rim of tub.

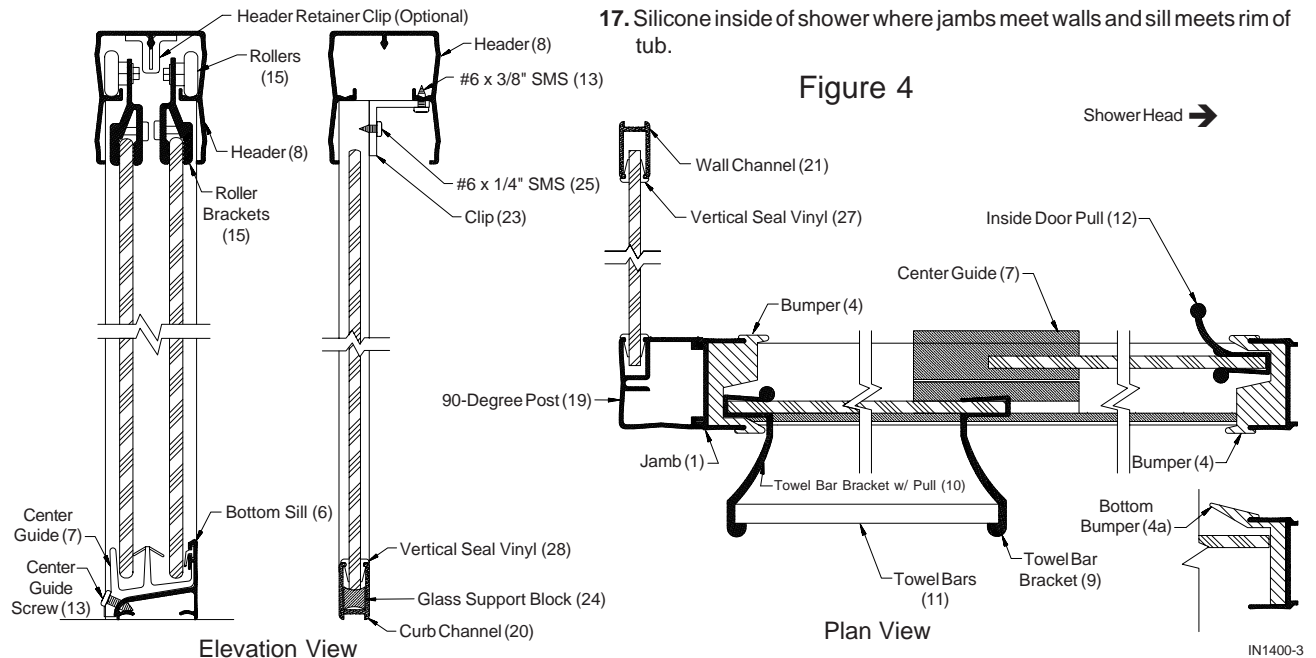

Figure 4