

INSTALLATION INSTRUCTIONS

Model Numbers

TUB / SHOWER ENCLOSURES
TE1500 / SE1500

HighLight Framed Bypass Tub / Shower Enclosure

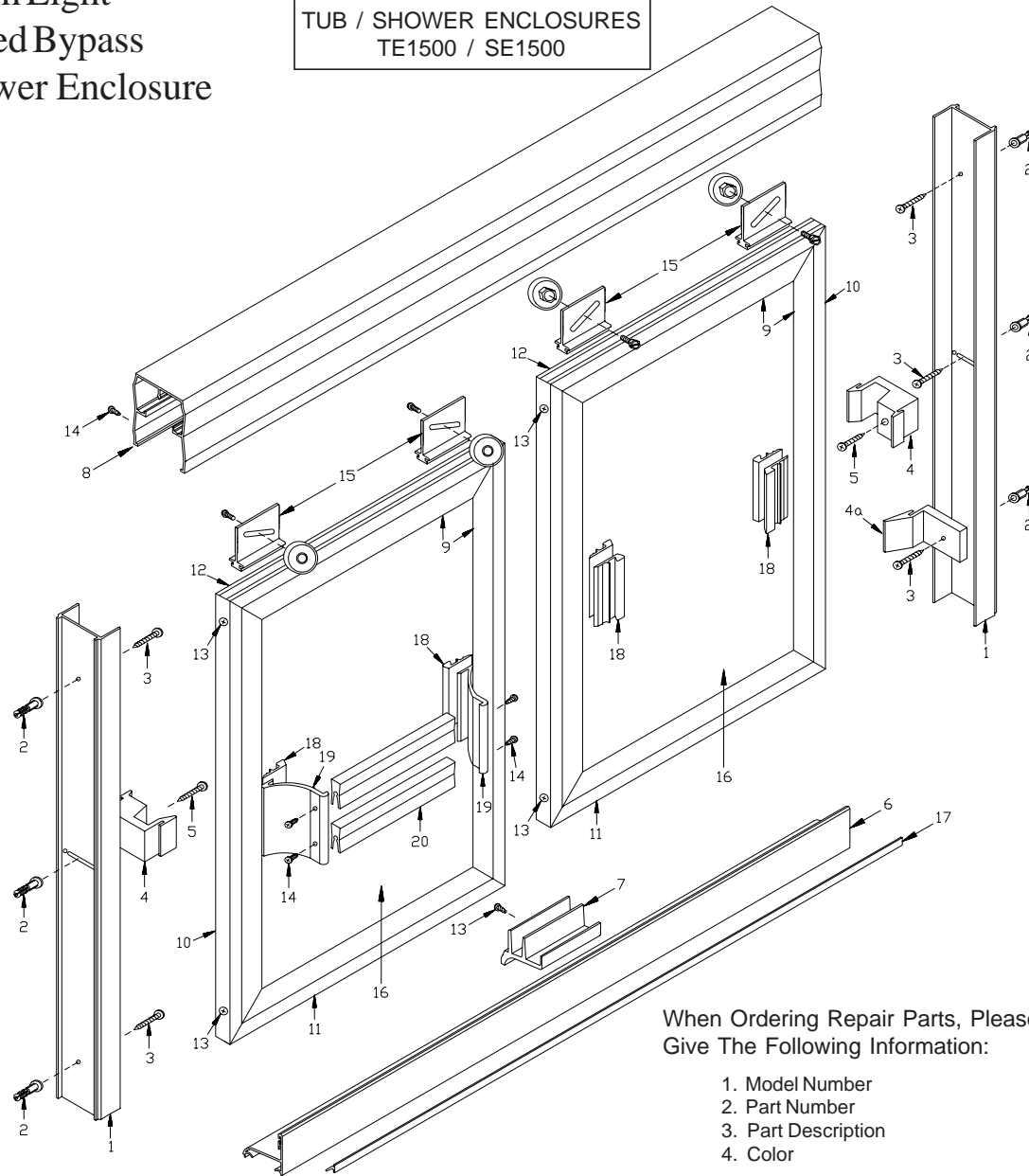

To install your shower enclosure, you will need the following:

- Level
- #31 Drill Bit
- 3/16" Carbide Drill Bit (for tile walls)
- Phillips Screwdriver
- Silicone
- Hack Saw
- 1/4" Box End Wrench

Description	Qty.	Part #	Picture
1. Wall Jamba	2	TE-1203	
2. Wall Anchors	6	HWANCHOR	
3. #8 x 1 1/2" SMS Screws	6	#8 x 1 1/2" SMS	
4. Door Bumpers	2	V-924	
4a. Bottom Bumper	1	V-926	
5. #6 x 1/2" SMS Screws	2	#6 x 1/2" SMS	
6. Sill	1	TE-1522	
7. Center Guide - 3"	1	V-529	
8. Header	1	TE-1201	
9. Glazing Vinyl		V-542	
10. Vertical Rail	4	TE-1507	
11. Bottom Rail	2	TE-1501	
12. Top Rail	2	TE-1501	
13. #8 x 1 1/4" Lead Point Screws	8	#8 x 1 1/4" LPS	
14. #6 x 3/8" SMS Screws	7	#6 x 3/8" SMS	
15. Roller Bracket Assembly	4	TE-1511	
16. Glass Panels	2		
17. Bottom Sill Vinyl Door Guide	1	V-528	
18. Slider Pulls	6	TE-1510	
19. Towel Bar Brackets	2	TE-1512	
20. Towel Bars	2	TE-1205	

When Ordering Repair Parts, Please
Give The Following Information:

1. Model Number
2. Part Number
3. Part Description
4. Color

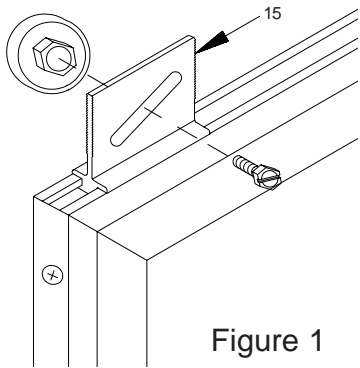
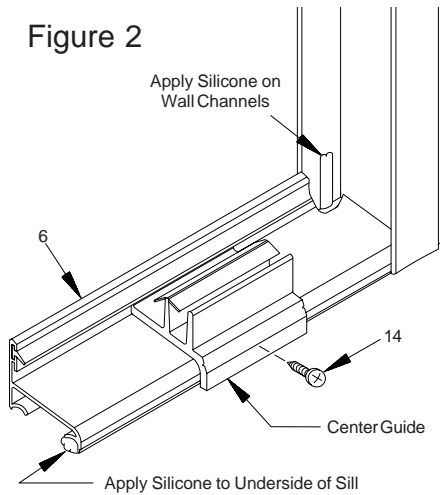

Figure 1

1. Set Wall Jamb (1) in place on walls, centering bottom of jamb on rim of tub. Hold plumb and mark walls for screw holes.
2. Remove and drill 3/16" diameter holes in walls (use a carbide tipped drill bit for tile walls). Insert plastic wall anchors (2) into holes. Silicone where the wall meets the rim of the tub to seal the bottom of jamb. Set jambs in place and secure to the wall with #8 x 1 1/2" screws (3). Secure bottom bumper (4a) on showerhead/ Inside side with the bottom wall jamb screw.
3. Cut sill (6) to fit opening between jambs.

Run a bead of silicone full length to the underside of sill (See Figure 2) and apply silicone to inside of jamb where jamb meets tub. On inside of jamb, run a 1/4" bead of silicone 1 1/4" up the outside leg of each wall jamb. Set sill in place and press firmly to rim of tub. Wipe off any excess silicone before curing. Use tape to hold in place until silicone has set.

Figure 2



4. Cut Header (8) 1/32" to 1/16" less than opening width and set in place.
5. To set slider glass in place, hold inside slider panel inside of tub or shower pan, obscure side facing out and insert rollers up into header and lower into place on the inside roller track in the header. The inside slider glass will close against the wall jamb on the shower head side. Next, insert lower end of outside slider in front of inside slider by pushing lower ends far enough in, to allow clearance on inside edge of tub or pan. Avoid roller bracket to roller bracket contact while lifting panel into place. The outside slider will close against the jamb opposite the showerhead.

6. Place center guide (7) to center position on sill (See Figure 2). Make sure the center guide is hooked into the slot position on the sill, then drill a hole using a #31 drill bit and fasten center guide to sill with the #6 x 3/8" screw (14) provided.

7. Close panels and adjust to align the vertical edge of panels with jambs. Using a 1/4" box-end wrench, loosen the screws on the rollers, but don't remove completely. When screws are loose, adjust panel by sliding the screw in the slot. Note: when screws are loose be sure to support panel so it does not fall and break. Adjust inside slider as low as possible to reduce the gap between bottom of slider and sill taking care that the glass does not drag on the track or center guide.

8. To set the slider pulls (18) and towel bar brackets (19), first remove any masking

tape that was used to hold the vinyl in place. Now on the inside slider, push or gently tap the four pulls (18) into place in the 3" gaps left between the two ends of the glazing vinyl (1).

9. Repeat Step #8 on the outside slider making sure that the towel bar brackets (19) are on the outside. Assemble towel bars (20) to towel bar brackets with four #6 x 3/8" SMS screws (14). (See Figure 3.)

10. Center hole in jamb is slotted to allow adjusting of jamb to compensate for bowed glass. After installing hardware, roll both panels into jamb on one side. If edge of metal hits on edge of jamb, loosen center screw and adjust jamb accordingly. Repeat on opposite side.

11. Secure bumpers (4) in place with a #6 x 1/2" screw (5). **NOTE:** Glass panels close into the recessed portion of the bumpers. The recess is toward the inside of the tub on the showerhead jamb, and toward the outside on the other jamb. From inside of unit, drill #31 holes through header and into wall jambs. Secure header to wall jambs with two #6 x 3/8" SMS screws (14).

12. Silicone inside of shower where jambs meet walls and sill meets rim of tub.

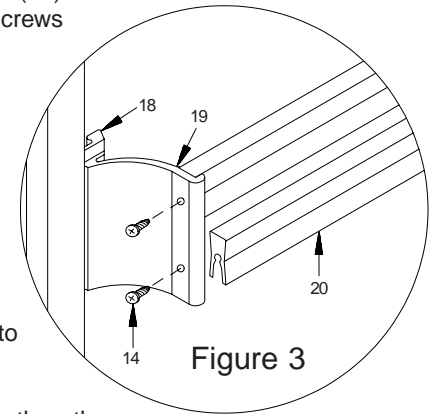

Figure 3

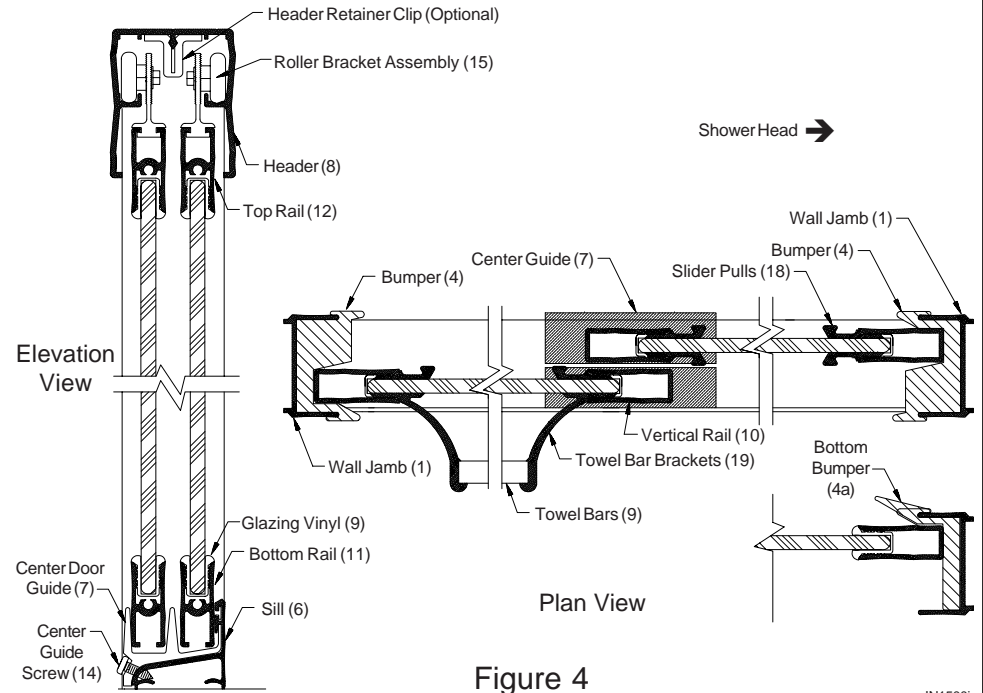

Figure 4

ASSEMBLY INSTRUCTIONS

Model Numbers

TUB / SHOWER ENCLOSURES
TE1500 / SE1500

HighLight Framed Bypass Tub / Shower Enclosure

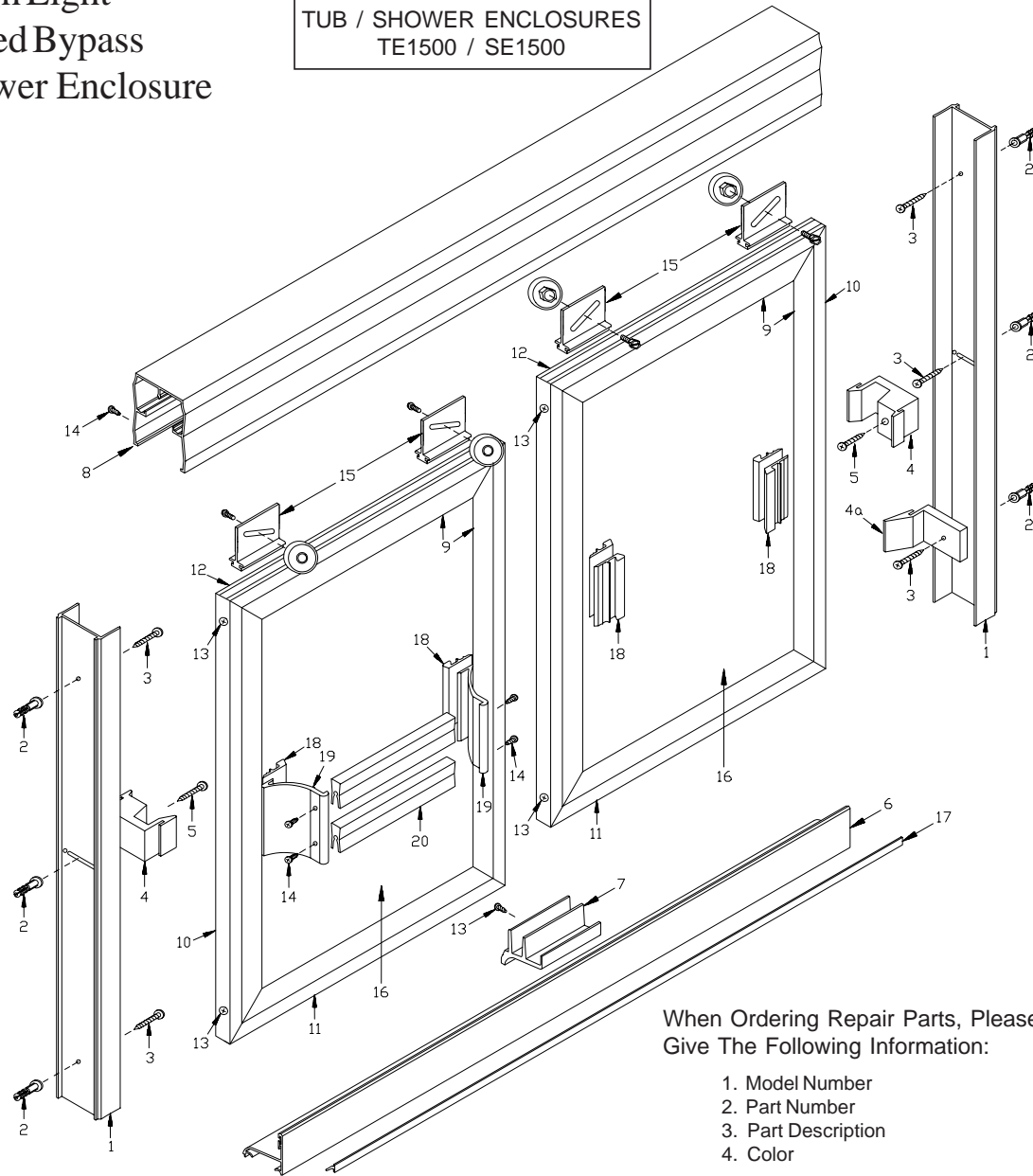

To install your shower enclosure, you will need the following:

- Level
- #31 Drill Bit
- 3/16" Carbide Drill Bit (for tile walls)
- Phillips Screwdriver
- Silicone
- Hack Saw

Description	Qty.	Part #	Picture
1. Wall Jamba	2	TE-1203	
2. Wall Anchors	6	HWANCHOR	
3. #8 x 1 1/2" SMS Screws	6	#8 x 1 1/2" SMS	
4. Door Bumpers	2	V-924	
4a. Bottom Bumper	1	V-926	
5. #6 x 1/2" SMS Screws	2	#6 x 1/2" SMS	
6. Sill	1	TE-1522	
7. Center Guide - 3"	1	V-529	
8. Header	1	TE-1201	
9. Glazing Vinyl		V-542	
10. Vertical Rail	4	TE-1507	
11. Bottom Rail	2	TE-1501	
12. Top Rail	2	TE-1501	
13. #8 x 1 1/4" Lead Point Screws	8	#8 x 1 1/4" LPS	
14. #6 x 3/8" SMS Screws	7	#6 x 3/8" SMS	
15. Roller Bracket Assembly	4	TE-1511	
16. Glass Panels	2		
17. Bottom Sill Vinyl Door Guide	1	V-528	
18. Slider Pulls	6	TE-1510	
19. Towel Bar Brackets	2	TE-1512	
20. Towel Bars	2	TE-1205	

When Ordering Repair Parts, Please Give The Following Information:

1. Model Number
2. Part Number
3. Part Description
4. Color

Figure 1

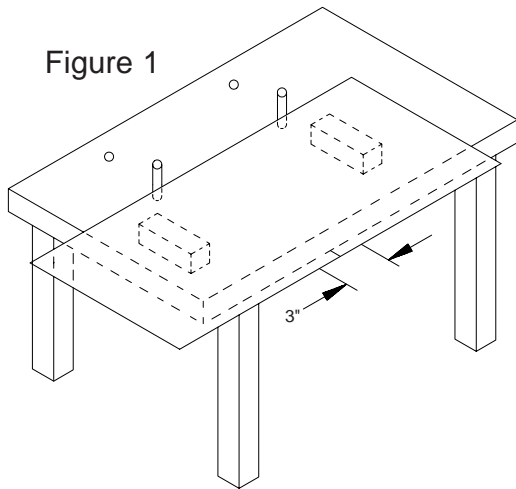

To give your framed Work Right SE/TE-1500 sliding enclosure as clean a look as possible, the handles are not attached with screws, but actually snap into place between the glass and the glass rail. To accomplish this, the glazing vinyl can be notched or separated before metal rails are glazed or can be notched after the rails are glazed. Our recommendation is to separate the vinyl before glazing.

1. To assemble the outside panel, lay your slider glass on the assembly table against the stops, holding the long edge of the glass a few inches out from the edge of the glazing table. Note: If you are using obscure glass, the rough side of the glass should be facing up.

2. Find the center of long edge of glass on both sides and mark with a marker. Measure 1 1/2" in both directions from center and make marks leaving 3" between outer marks. (See Figure 1.)

3. Start glazing vinyl at one of these outer marks and glaze around end of glass to outer marker on opposite side of glass notching corners as shown. (See Figure 2.)

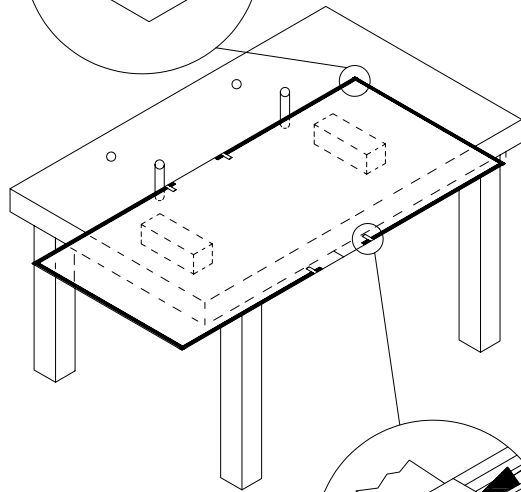
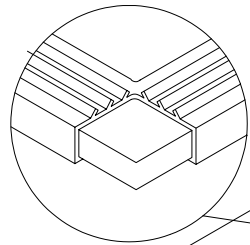
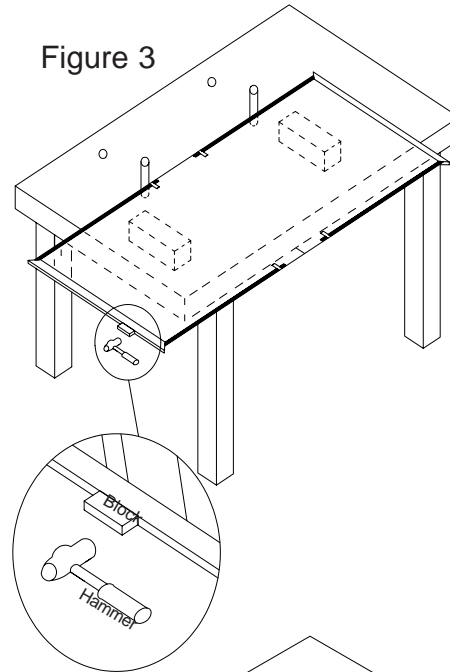

Figure 2

Figure 3



4. Leave 3" gap for future handle and start next piece of glazing vinyl at other outer mark and glaze around end of glass and stop at other outer mark, leaving a 3" gap from where you started. Notch corners as before. Ends of vinyl can be held in place with masking tape if you desire. (See Figure 2.)

5. Center top and bottom rails, and with a dead blow hammer or a steel hammer with a block of hardwood, gently drive rails on to the vinyl. (See Figure 3.)

6. Center first vertical rail and drive on to vinyl. Turn panel around and before driving second vertical rail on, insert two roller brackets (14) into top rail with the rollers facing same side as rough side of glass if using obscure glass. Drive second vertical rail on to vinyl and secure all four corners with #8 x 1 1/4" lead point screws (13). (See Figure 4.)

Figure 4

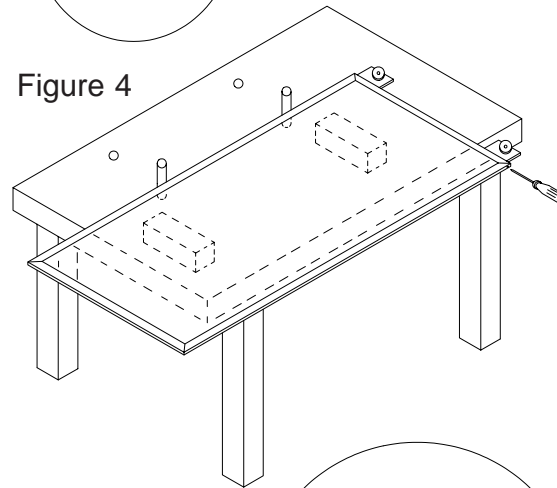

7. Now crimp the roller brackets as shown in (Figure 5.)

8. For inside slider, follow steps #1 through #6 except that rollers will face same side as smooth side of glass if using obscure glass.

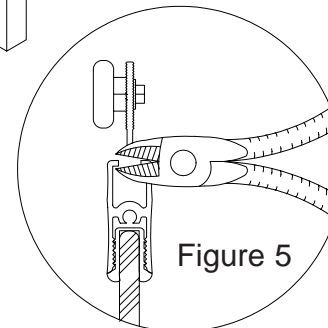

Figure 5