

INSTALLATION INSTRUCTIONS

Model Numbers

TUB / SHOWER ENCLOSURES
TE1500-4 / SE1500-4

High Light Series Framed Bypass Tub / Shower Enclosure

When Ordering Repair Parts, Please Give The Following Information:

1. Model Number
2. Part Number
3. Part Description
4. Color

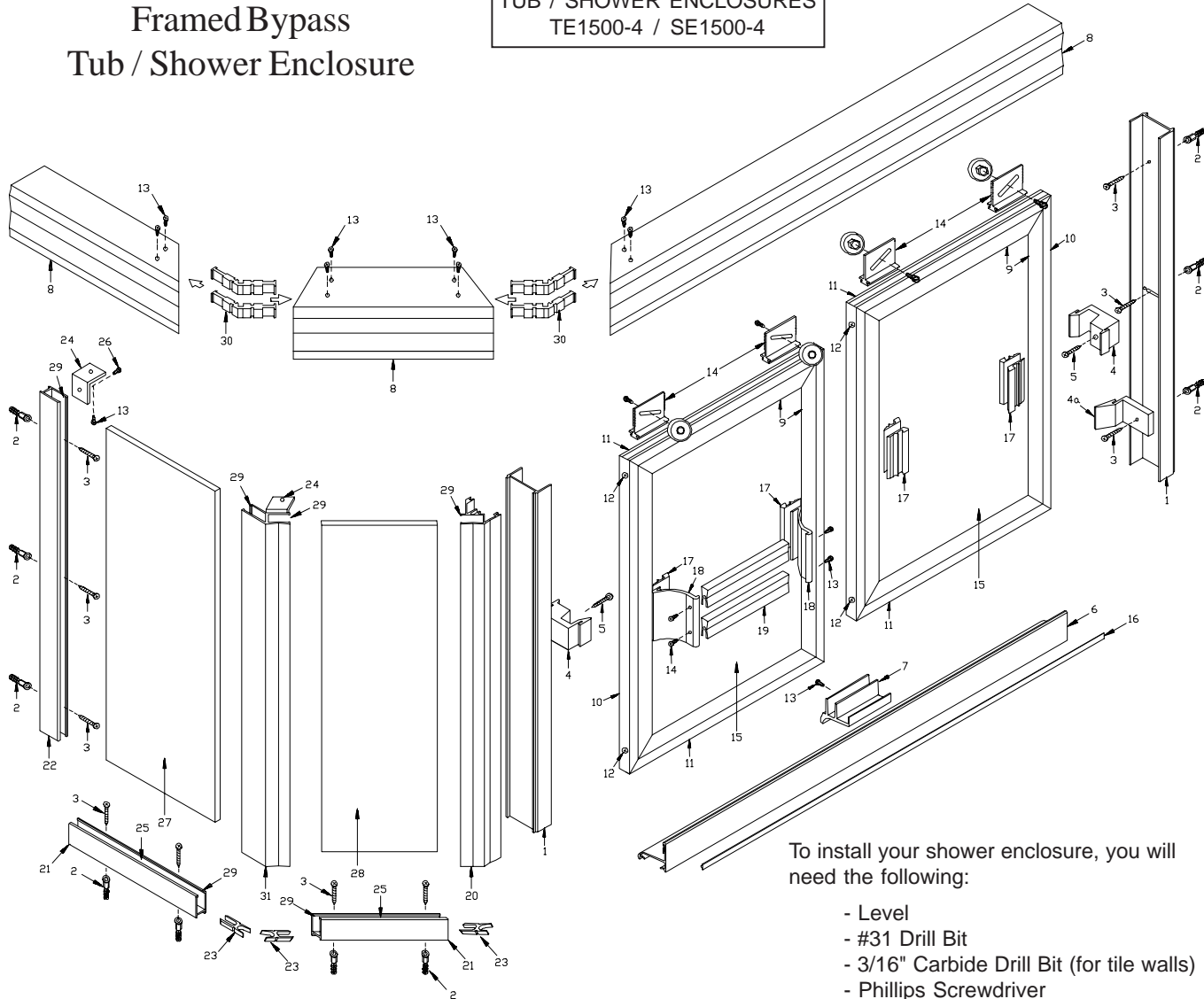

To install your shower enclosure, you will need the following:

- Level
- #31 Drill Bit
- 3/16" Carbide Drill Bit (for tile walls)
- Phillips Screwdriver
- Silicone
- Hack Saw
- 1/4" Box End Wrench

Description	Qty.	Part #	Picture
1. Wall Jamba	2	TE-1203	
2. Wall Anchors	8	HWANCHOR	
3. #8 x 1 1/2" SMS Screws	8	#8 x 1 1/2" SMS	
4. Door Bumpers	2	V-924	
4a. Bottom Bumper	1	V-926	
5. 6-32 x 1/2" MS Screws	2	6-32 x 1/2" MS	
6. Bottom Sill (with V-528)	1	TE-1522	
7. Center Guide - 3"	1	V-529	
8. Headers - Mitered	3	TE-1201	
9. Glazing Vinyl		V-542	
10. Vertical Rails	4	TE-1507	
11. Top & Bottom Rails	4	TE-1501	
12. #8 x 1 1/4" LPS Screws	8	#8 x 1 1/4" LPS	
13. #6 x 3/8" SMS Screws	10	#6 x 3/8" SMS	
14. Roller Bracket Assembly	4	TE-1511	
15. Glass Panels	2		
16. Bottom Sill Vinyl Door Guide	1	V-528	
17. Slider Pulls	6	TE-1510	
18. Towel Bar Brackets	2	TE-1512	
19. Towel Bars	1	TE-1205	
20. 135-Degree Post	1	TE-1215	
21. Curb Channels	2	D-1006	
22. Wall Channel	1	D-1006	
23. Post To Curb Keys	3	C-180-3/16	
24. Wall Channel-to-Header Clips	2	D-90-15/16	
25. Glass Support Blocks	2	V-902	
26. #6 x 1/4" SMS B Screws	1	#6x1/4SMSB	
27. 90-Degree Glass Panel	1		
28. 135-Degree Glass Panel	1		
29. Vertical Seal Vinyl	6	V-909	
30. 135-Degree Header Clip	2	A-1353132	
31. 135-Degree Post	1	SS-1105	

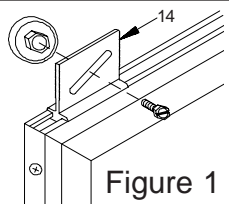

Figure 1

1. Draw a line on center of rim of tub or curb. Draw a parallel line $\frac{3}{4}$ " to outside of center line. This new line represents the outside dimension of the unit. Use this line for placement and cutting of 90-degree curb channel and 135-degree curb channel.

2. Measure out from wall (end panel side) to intersection of diagonal panel, deduct $\frac{15}{16}$ " and use this measurement to cut 90-degree curb channel to length. Apply a bead of silicone full length to underside of curb channel and set in place (weep holes to inside).

3. Set wall channel (22) in place on curb channel, hold plumb and mark wall for screw hole locations. Drill holes and insert plastic screw anchors (2). Fill curb channel with silicone where curb channel meets wall, set wall channel (22) in place and secure with #8 x $1\frac{1}{2}$ " screws (3). Secure header clip (21) to top inside leg of wall channel with a #6 x $\frac{1}{4}$ " SMS (26).

4. Place glass support blocks (25) in place in 90-degree curb channel (21). Set panel (27) in place in curb channel and wall channel. Hold in place, at top only with vertical seal vinyl (29).

5. Silicone curb where 135 post (31) will set. Insert post to curb key (23) into end of 90 curb channel and set post in place over edge of panel. Hold plumb and secure in place at top only, with vertical seal vinyl. Secure header clip (24) with a #6 x $\frac{1}{4}$ " screw (26).

6. Measure from post to point where diagonal and front curb lines meet. Deduct $\frac{7}{8}$ " from this measurement to cut 135-degree curb channel to length. If contoured surface of 135 post is on this center panel, compress short legs of post to curb key about $\frac{1}{16}$ " and drop down into position from the top of the 135 post, secure 135-degree curb channel in place just like 90-degree curb channel. Place a glass support block (24) in place in curb channel. Set panel (28) in curb channel and 135 post. Hold in place, at top only, with small wedge vinyl. Insert post to curb key (23) into end of curb channel.

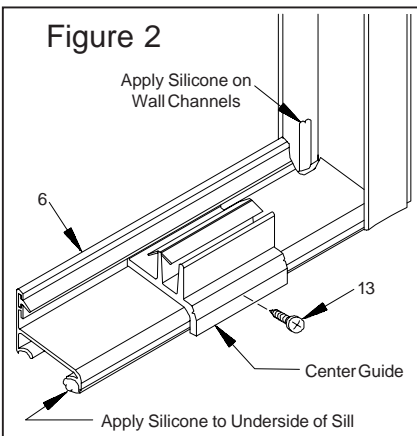

Figure 2

7. Silicone curb where 135 slider post (20) will set. Set post in place over edge of panel, hold plumb, and secure in place, at top only, with small wedge vinyl (29).

8. Set jamb (1) in place at wall opposite end panels, hold plumb and mark screw hole locations. Drill holes in wall and insert plastic screw anchors (2). Apply silicone where curb meets wall, set jamb in place and secure with #8 x $1\frac{1}{2}$ " SMS (3). Secure bottom bumper with bottom jamb screw.

9. Measure from inside of jamb to inside of 135 post slider post (20) and use this measurement to cut guide to length. Slide or snap center guide onto guide to one side of center. Run bead of caulk full length to underside of guide also to inside of jamb and post to seal ends of guide, then press guide firmly in place.

10. Cut center section of header (8) to length and assemble header using 135 clips (30) and #6 x $\frac{3}{8}$ " SMS (13). Cut header to length and set in place over jambs, post and wall channel. Secure header to jamb and slider post with #6 x $\frac{3}{8}$ " screws from inside of shower also to 135 post and wall channel with #6 x $\frac{3}{8}$ " screws. Insert vertical seal vinyl into wall channels, post and curb channels on both sides of panels.

11. Secure bumpers (4) with 6-32 x $\frac{1}{2}$ " screws (5). Raised portion of bumper to outside at shower head side to inside at

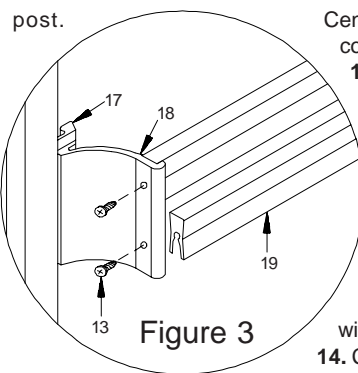

Figure 3

post.

Center hole in jamb is slotted to allow jamb to be moved in or out to compensate for bowed glass.

12. To set slider glass in place, hold inside slider panel inside of tub or shower pan, insert rollers up into header and lower into place. Next, insert lower end of outside slider in front of inside slider by pushing lower ends far enough in, to allow clearance on inside edge of tub or pan. Avoid roller bracket to roller bracket contact while lifting panel into place. The outside slider will close against the jamb opposite the showerhead.

13. Place center guide (7) to center position on sill (6). Make sure the center guide is hooked into the slot position on the sill, then drill a hole using a #31 drill bit and fasten center guide to sill with the #6 x $\frac{3}{8}$ " screw (13) provided.

14. Close panels and adjust to align the vertical edge of panels with jamb and post. Using a $\frac{1}{4}$ " box-end wrench, loosen the screws on the

rollers, but don't remove completely. When screws are loose, adjust panel by sliding the screw in the slot. **Note:** when screws are loose be sure to support panel so it does not fall and break. Adjust inside slider as low as possible to reduce the gap between bottom of slider and sill taking care that the glass does not drag on the track or center guide. Adjust for bowed glass by using the slotted hole in the jamb. Secure bumpers to the jambs using 6-32 x $\frac{1}{2}$ " screw (5).

15. To set the slider pulls (17) and towel bar brackets (18), first remove any masking tape that was used to hold the vinyl in place. Now on the inside slider, push or gently tap the four pulls (17) into place in the 3" gaps left between the two ends of the glazing vinyl (9).

16. Repeat Step #13 on the outside slider making sure that the towel bar brackets (18) are on the outside. Assemble towel bars (19) to towel bar brackets with four #6 x $\frac{3}{8}$ " SMS screws (13). (See Figure 3.)

17. Silicone inside of shower where jambs meet walls and sill meets rim of tub.

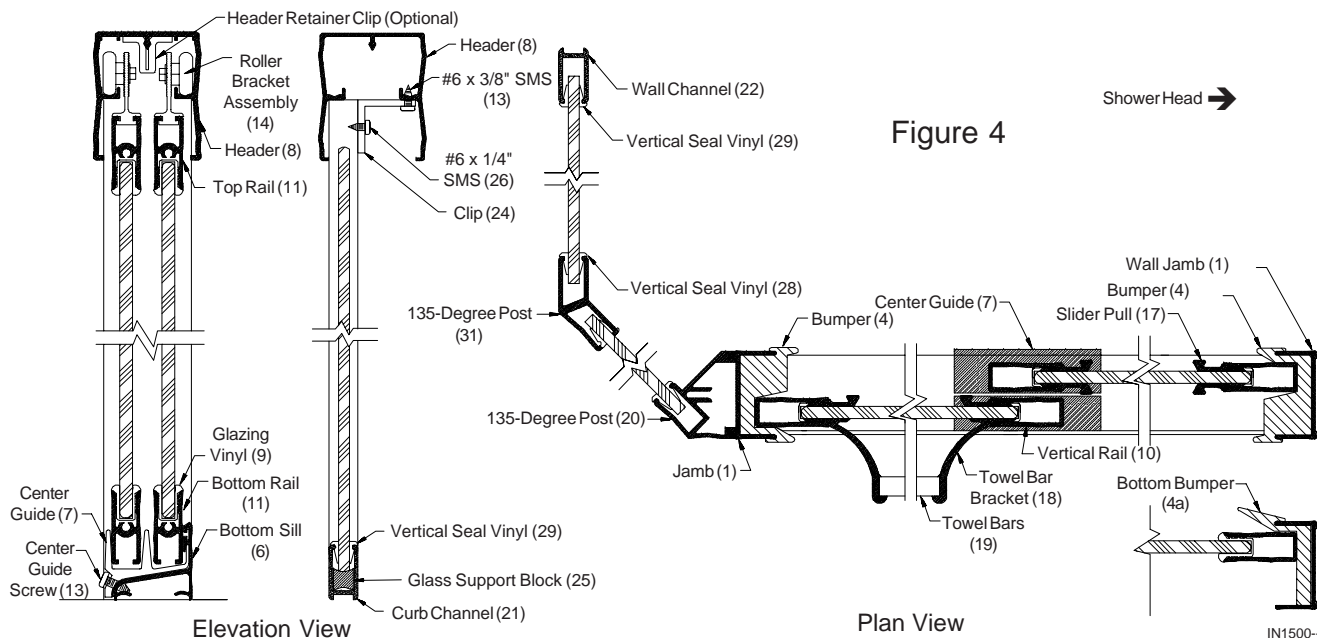

Figure 4

Elevation View

Plan View