

INSTALLATION INSTRUCTIONS

Model Numbers

TUB / SHOWER ENCLOSURES
TE1600-2 / SE1600-2

Prestige Series Frameless Bypass Tub / Shower Enclosure

When Ordering Repair Parts, Please
Give The Following Information:

1. Model Number
2. Part Number
3. Part Description
4. Color

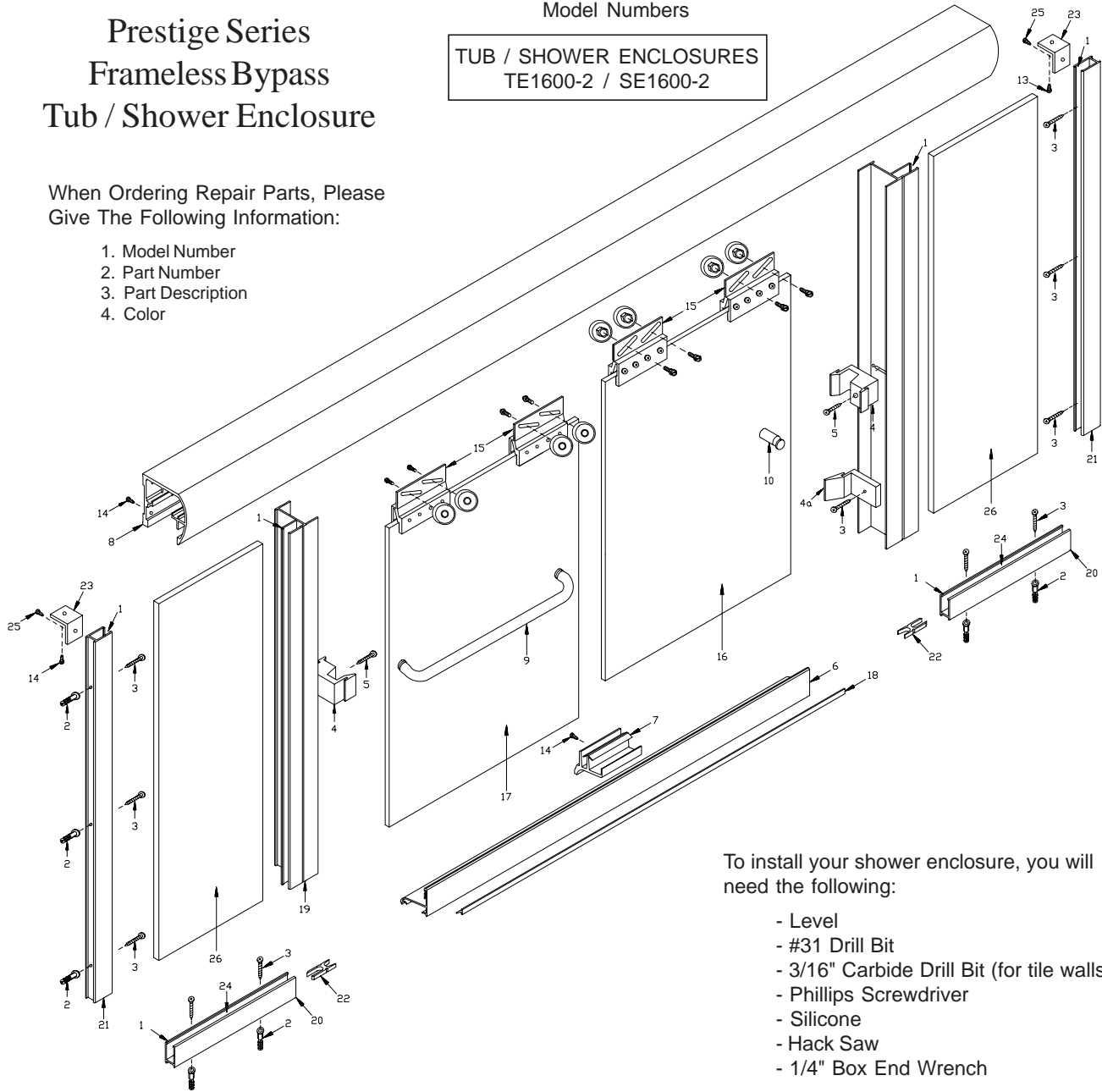

To install your shower enclosure, you will
need the following:

- Level
- #31 Drill Bit
- 3/16" Carbide Drill Bit (for tile walls)
- Phillips Screwdriver
- Silicone
- Hack Saw
- 1/4" Box End Wrench

Description	Qty.	Part #	Picture
1. Vertical Seal Vinyl	12	V-909	
2. Wall Anchors	8	HWANCHOR	
3. #8 x 1 1/2" SMS Screws	8	#8 x 1 1/2" SMS	
4. Door Bumpers	2	V-924	
4a. Bottom Bumper	1	V-926	
5. 6-32 x 1/2" MS	2	6-32 x 1/2" MS	
6. Bottom Sill (With V-918)	1	TE-1522	
7. Center Guide - 3"	1	V-530	
8. Header	1	TE-1601	
9. Tubular Towel Bar	1	TE-1605	
10. Solid Tubular Inside Pull	1	TE-1607	
11. Towel Bar Pull Fastener	3	1/4-20	
12. Nylon Towel Bar Washers	6	3/4" nylon washer	
13. Nylon Towel Bar Sleeve	3	1/4" nylon sleeve	
14. #6 x 3/8" SMS	10	#6 x 3/8" SMS	
15. Double Roller Bracket Assm. - 3"	4	TE-1208-F	
16. Inside 1/4" Glass Panel with one 1/2" hole	1	Inside Slider	
17. Outside 1/4" Glass Panel with two 1/2" holes	1	Outside Slider	
18. Door Guide Vinyl (with TE-1522)	1	V-918	
19. 180-Degree Post	2	TE-1218	
20. Curb Channels	2	D-1006	
21. Wall Channels	2	D-1006	
22. Post To Curb Keys	2	C-180-3/16	
23. Clips	2	D-90-15/16	
24. Glass Support Blocks	2	V-902	
25. #6 x 1/4" SMS B Screws	2	#6x1/4SMSB	
26. Glass Panels	2		

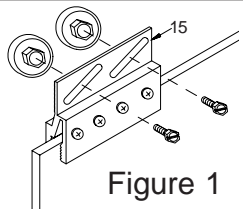

Note: Apply a bead of silicone (GE1200) into the open channel of roller bracket before attaching to glass. To assemble roller bracket (15) to glass, tighten screws until surface of roller bracket is depressed 1/32" (28 inchpounds of torque). Allow to cure for 24 hours before hanging sliders.

Figure 1

1. For 30" wide sliders deduct 60" from opening width and divide by two and subtract 7/8" to arrive at length of channel curbs (20).
2. Set channel curbs (20) temporarily in place on curb, inside edge of channel curb should be set 1/4" to outside of center of curb. Set wall channels (21) in place on curbs, hold plumb and mark screw hole locations.
3. Remove wall channels and channel curbs. Drill 3/16" holes in walls, and insert plastic screw anchors (2).

4. Run bead of silicone full length, to underside of channel curbs (20). Set channel curbs in place with weep holes to the inside. Fill channel with silicone where curb meets wall. Set wall channels in place and secure with # 8 x 1 1/2" SMS (3). Secure clips (23) to top inside of wall channels with a #6 x 1/4" SMS (25).

5. Place glass support block (24) in center of channel curbs. Set panels (26) in place in curbs and into wall channels. Insert post to curb keys (22)
6. Caulk curb where 180-degree post (19) will set. Fill channel of 180-degree post with silicone, opposite bumper location, to help support post on panel. Set 180-degree post in place over edge of panel, hold plumb and insert vertical seal vinyl (1) into wall channel and post on both sides of panel. Insert vertical seal vinyl into channel curb on both sides of panel.

Figure 2

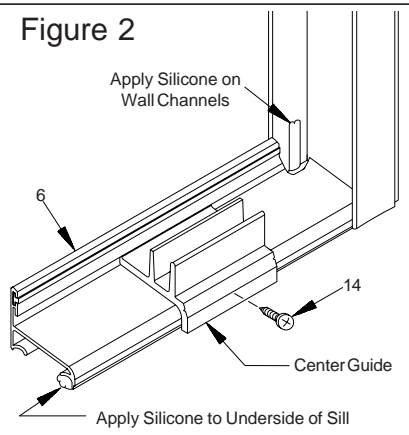

7. Measure between 180-degree post (19) at the curb and use this measurement to cut bottom sill (6) to length. Run a bead of silicone, full length to underside of sill and press firmly in place on curb.

8. Cut header (8) 1/32 to 1/16" less than opening width and set in place over 180-degree posts and wall channels. Secure header to 180-degree posts and wall channel clips (23) with #6 x 3/8" SMS (14)
9. To set slider glass in place, hold inside slider panel (16) inside of tub or shower pan, insert rollers up into header and lower into place. Next,

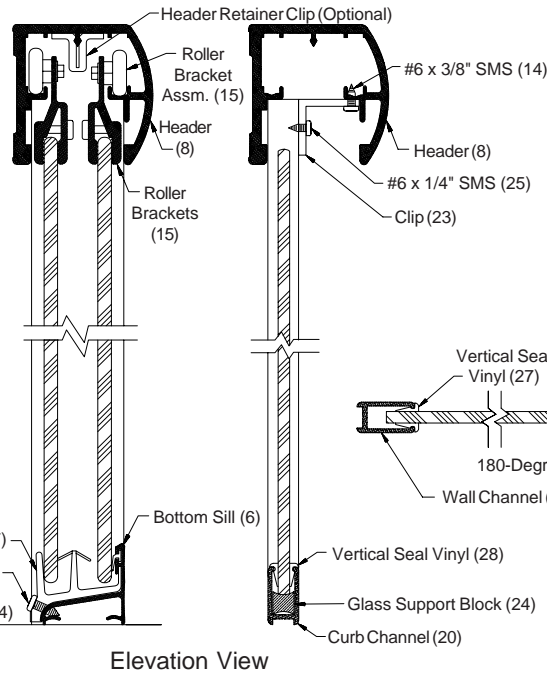

Elevation View

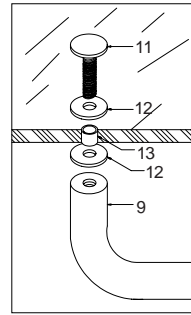

Outside Door Panel

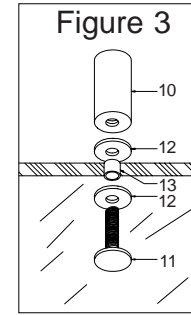

Inside Door Panel

Figure 3

insert lower end of outside slider (17) in front of inside slider by pushing lower ends far enough in, to allow clearance on inside edge of tub or pan. Avoid roller bracket to roller bracket contact while lifting panel into place. The outside slider will close against the jamb opposite the showerhead. Slide center guide (7) onto center of sill.

10. Close panels and adjust to align the vertical edge of panels 180-degree posts. Using a 1/4" box-end wrench, loosen the screws on the rollers, but don't remove completely. When screws are loose, adjust panel by sliding the screw in the slot. **Note:** when screws are loose be sure to support panel so it does not fall and break.

Adjust inside slider as low as possible to reduce the gap between bottom of slider and sill taking care that the glass does not drag on the sill (6) or center guide (7). Adjust for bowed glass by using the slotted hole in the jamb. Secure bumpers (4) to the jambs using 6-32 x 1/2" screws (5).

13. To install towel bar (9), place nylon towel bar insert sleeves (13) into holes in the glass (17). Next, hold the tubular towel bar (9) against the hole in the glass with the nylon towel bar/pull washer (12) between the glass and the towel bar. Place a nylon towel bar/pull washer on the towel bar/pull screw (11) and secure towel bar in place on both ends. Install the pull the same way the towel bar was installed. Use hole in fastener to tighten (See Figure 3).

14. Silicone inside of shower where jambs meet walls and sill meets rim of tub.

Figure 4

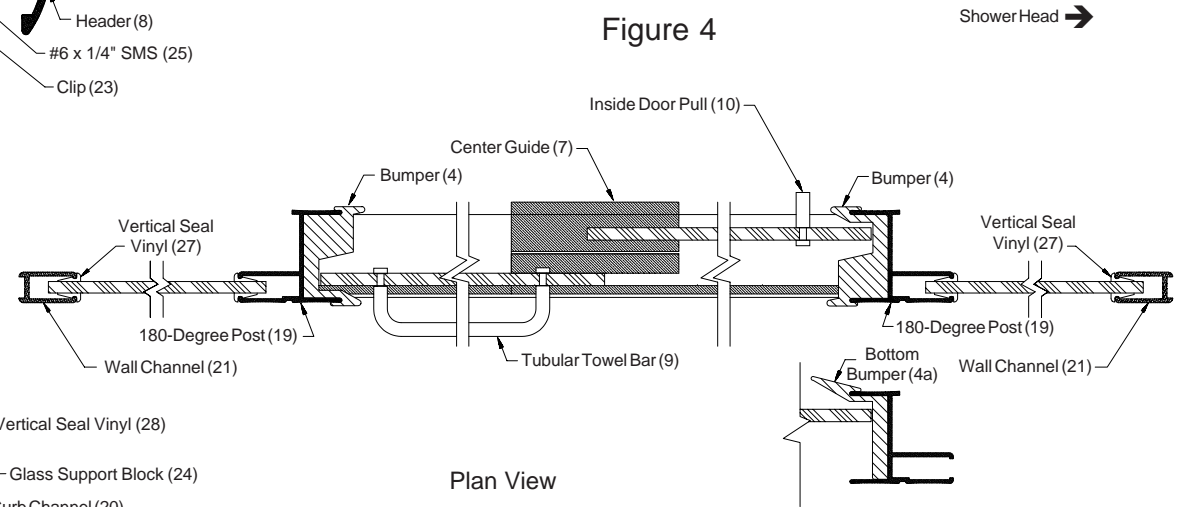

Plan View