

# INSTALLATION INSTRUCTIONS

Model Numbers

TUB / SHOWER ENCLOSURES  
TE1600-4 / SE1600-4

## Prestige Series Frameless Bypass Tub / Shower Enclosure

When Ordering Repair Parts, Please  
Give The Following Information:

1. Model Number
2. Part Number
3. Part Description
4. Color

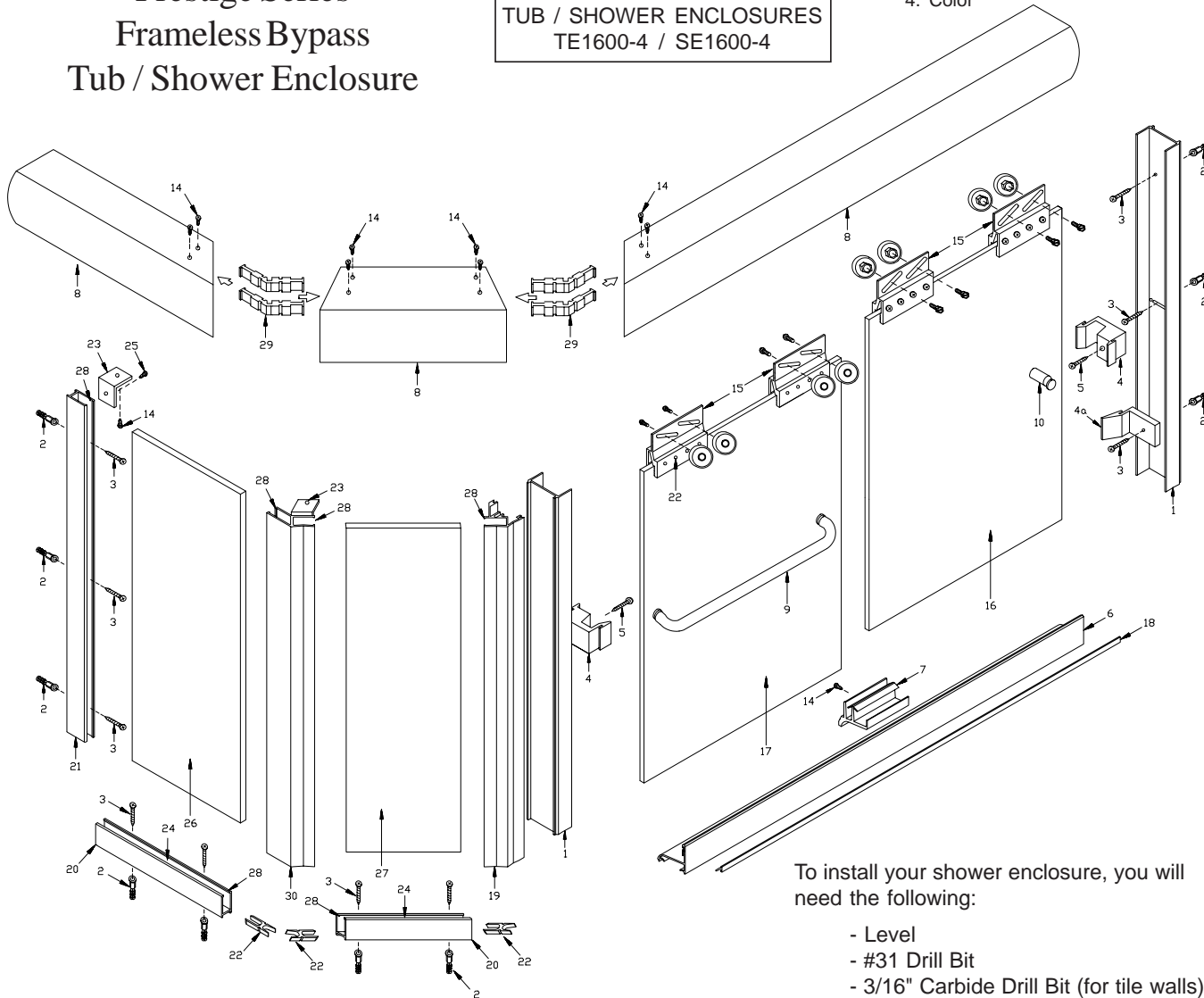

To install your shower enclosure, you will need the following:

- Level
- #31 Drill Bit
- 3/16" Carbide Drill Bit (for tile walls)
- Phillips Screwdriver
- Silicone
- Hack Saw
- 1/4" Box End Wrench

Description	Qty.	Part #	Picture
1. Wall Jamba	2	TE-1203	
2. Wall Anchors	11	HWANCHOR	
3. #8 x 1 1/2" SMS Screws	11	#8 x 1 1/2"SMS	
4. Door Bumpers	2	V-924	
4a. Bottom Bumper	1	V-926	
5. 6-32 x 1/2" MS Screws	2	6-32 x 1/2" MS	
6. Bottom Sill (with V-918)	1	TE-1522	
7. Center Guide - 3"	1	V-530	
8. Headers - Mitered	2	TE-1601	
9. Tubular Towel Bar	1	TE-1605	
10. Solid Tubular Inside Pull	1	TE-1607	
11. Towel Bar Pull Fastener	5	1/4-20	
12. Nylon Towel Bar Washers	6	3/4" nylon washer	
13. Nylon Towel Bar Sleeve	3	1/4" nylon sleeve	
14. #6 x 3/8" SMS	10	#6 x 3/8" SMS	
15. Double Roller Bracket Assm. - 3"	4	TE-1208-F	
16. Inside 1/4" Glass Panel with one 1/2" hole	1	Inside Slider	
17. Outside 1/4" Glass Panel with two 1/2" holes	1	Outside Slider	
18. Door Guide Vinyl (with TE-1522)	1	V-918	
19. 135-Degree Post	1	TE-1215	
20. Curb Channels	2	D-1006	
21. Wall Channel	1	D-1006	
22. Post To Curb Keys	3	C-180-3/16	
23. Clips	2	D-90-15/16	
24. Glass Support Blocks	3	V-902	
25. #6 x 1/4" SMS B Screws	2	#6x1/4SMSB	
26. 90-Degree Glass Panel	1		
27. 135-Degree Glass Panel	1		
28. Vertical Seal Vinyl	12	V-909	
29. 135-Degree Header Clip	4	A-1353132	
30. 135-Degree Post	1	SS-1105	

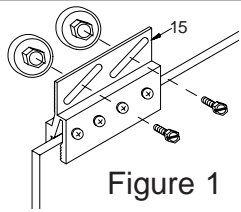

Note: Apply a bead of silicone (GE1200) into the open channel of roller bracket before attaching to glass. To assemble roller bracket (15) to glass, tighten screws until surface of roller bracket is depressed 1/32" (28 inchpounds of torque). Allow to cure for 24 hours before hanging sliders.

1. Draw a line on center of rim of tub or curb. Draw a parallel line 3/4" to outside of center line. This new line represents the outside dimension of the unit. Use this line for placement and cutting of 90-degree curb channel and 135-degree curb channel.

2. Measure out from wall (end panel side) to intersection of diagonal panel, deduct 15/16" and use this measurement to cut 90-degree curb channel to length. Apply a bead of silicone full length to underside of curb channel and set in place (weep holes to inside).

3. Set wall channel (21) in place on curb channel, hold plumb and mark wall for screw hole locations. Drill holes and insert plastic screw anchors (2). Fill curb channel with silicone where curb channel

meets wall, set wall channel (21) in place and secure with #8 x 1 1/2" screws (3). Secure header clip (23) to top inside leg of wall channel with a #6 x 1/4" SMS (25).

4. Place glass support blocks (24) in place in 90-degree curb channel. Set panel (26) in place in curb channel and wall channel. Hold in place, at top only with vertical seal vinyl (28).

5. Silicone curb where 135 post (30) will set. Insert post to curb key (22) into end of 90 curb channel and set post in place over edge of panel. Hold plumb and secure in place at top only, with small wedge vinyl. Secure header clip (23) with a #6 x 1/4" screw (25).

6. Measure from post to point where diagonal and front curb lines meet. Deduct 7/8" from this measurement to cut 135-degree curb channel to length. If contoured surface of 135 post is on this center panel, compress short legs of post to curb key about 1/16" and drop

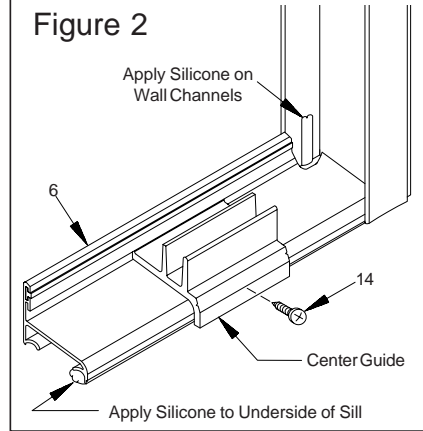

down into position from the top of the 135 post, secure 135-degree curb channel in place just like 90-degree curb channel. Place a glass support block (24) in place in curb channel. Set panel (27) in curb channel and 135 post. Hold in place, at top only, with small wedge vinyl. Insert post to curb key (22) into end of curb channel.

7. Silicone curb where 135 slider post (19) will set. Set post in place over edge of panel, hold plumb, and secure in place, at top only, with small wedge vinyl (28).

8. Set jamb (1) in place at wall opposite end panels, hold plumb and mark screw hole locations. Drill holes in wall and insert plastic screw anchors (2). Apply silicone where curb meets wall, set jamb in place and secure with #8 x 1 1/2" SMS (3). Secure bottom bumper with bottom jamb screw.

9. Measure from inside of jamb to inside of 135 post slider post (19) and use this measurement to cut guide to length. Slide or snap center guide onto guide to one side of center. Run bead of caulk full length to underside of guide also to inside of jamb and post to seal ends of guide, then press guide firmly in place.

10. Cut center section of header (8) to length and assemble header using 135 clips (24) and #6 x 3/8" SMS (14). Cut header to length and set in place over jambs, post and wall channel. Secure header to jamb and slider post with #6 x 3/8" screws from inside of shower also to 135 post and wall channel with #6 x 3/8" screws. Insert vertical seal vinyl into wall channels, post and curb channels

Insert vertical seal vinyl into wall channels, post and curb channels

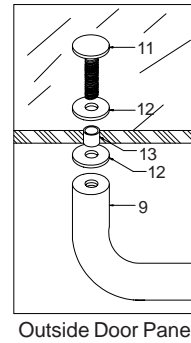

Outside Door Panel

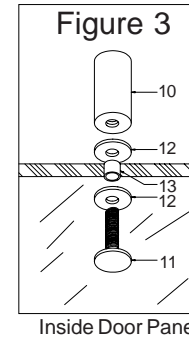

Inside Door Panel

on both sides of panels.

11. Secure bumpers (4) with 6-32 x 1/2" screws (5). Raised portion of bumper to outside at shower head side to inside at post. Center hole in jamb is slotted to allow jamb to be moved in or out to compensate for bowed glass.

12. To set slider glass in place, hold inside slider panel (16) inside of tub or shower pan, insert rollers up into header and lower into place. Next, insert lower end of outside slider (17) in front of inside slider by pushing lower ends far enough in, to allow clearance on inside edge of tub or pan. Avoid roller bracket to roller bracket contact while lifting panel into place. The outside slider will close against the jamb opposite the showerhead.

13. Place center guide (7) to center position on sill (6). Make sure the center guide is hooked into the slot position on the sill, then drill a hole using a #31 drill bit and fasten center guide to sill with the #6 x 3/8" screw (14) provided.

14. Close panels and adjust to align the vertical edge of panels with jamb and post. Using a 1/4" box-end wrench, loosen the screws on the rollers, but don't remove completely. When screws are loose, adjust panel by sliding the screw in the slot. Note: when screws are loose be sure to support panel so it does not fall and break. Adjust inside slider as low as possible to reduce the gap between bottom of slider and sill taking care that the glass does not drag on the track or center guide. Adjust for bowed glass by using the slotted hole in the jamb. Secure bumpers to the jambs using 6-32 x 1/2" screw (5).

15. To install towel bar (9), place nylon towel bar insert sleeves (13) into holes in the glass (17). Next, hold the tubular towel bar (9) against the hole in the glass with the nylon towel bar/pull washer (12) between the glass and the towel bar. Place a nylon towel bar/pull washer on the towel bar/pull screw (11) and secure towel bar in place on both ends. Install the pull the same way the towel bar was installed. Use hole in fastener to tighten (See Figure 3).

16. Silicone inside of shower where jambs meet walls and sill meets rim of tub.

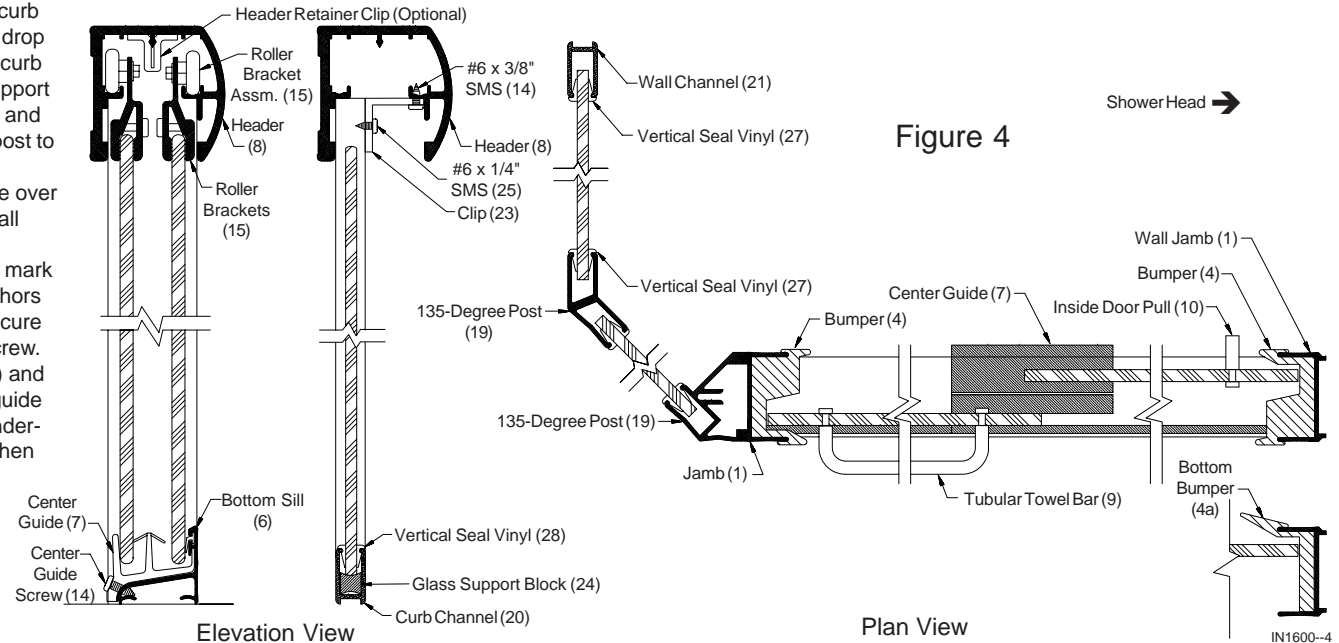

Elevation View

Plan View